



IT / UK

Modello - Model

**CHF 900 DD**

Marca - Brand

Categoria - Category

**Congelatore Orizzontale per Supermarket**  
**Horizontal Supermarket Freezer**

**COPERTINA / COVER**

Vista / View





<b>IT / UK</b>	Modello - Model	<b>CHF 900 DD</b>			
	Marca - Brand				
	Categoria - Category	<b>Congelatore Orizzontale per Supermarket</b> <b>Horizontal Supermarket Freezer</b>			

**DATI TECNICI / TECHNICAL DATA**

Specifiche Tecniche	Technical Specifications	[Unità] / [Units]	IT	UK
Standard di riferimento	Technical Specifications	-	EN23953	
Classe Climatica	Climate Class	-	7 (35°C - 75% R.H.) - EN23953	
Classe di Temperatura	Temperature Class	-	L1 - EN23953 / EN16838	
Condizioni Ambiente	Ambient conditions	[°C - R.H.]	(Θ <sub>ah</sub> ≤ -15°C - Θ <sub>al</sub> ≤ -18°C)	
Classe di Sicurezza (EN 60335)	Safety Class (according to EN 60335)	-	5 (43 °C)	
Intervallo di Regolaz. Temp. interna	Adjustable interior temp.range	[°C]	-23 / -18	
Consumo Energetico	Energy Consumption	[kWh/24h]	2,96	
Tensione / Frequenza	Voltage / Frequency	[V / Hz]	220-240 / 50	
Potenza Nominale	Rated Power	[W]	235	
Corrente Nominale	Rated Current	[A]	1,65	
Potenza in Sbrinamento	Defrosting Power	[W]	-	
Corrente in Sbrinamento	Defrosting Current	[A]	-	
Potenza Luci	Total Power of Lights	[W]	15	
Potenza Resistenze Elettriche	Total Power of Electrical Heaters	[W]	-	
% di funzionamento Compressore	Relative Running Time	[%]	63,0	
Livello di Rumorosità	Noise level	[dB(A)]	58	

Gruppo Refrigerazione	Refrigerating Group	[Unità] / [Units]	IT	UK
Nr Compressori	Nr of Compressors	-	1	
Compr. #1 Tipo di Refrigerante	Compr. #1 Refrigerant Type	-	R290	
Compr. #1 Quantità di Refrigerante	Compr. #1 Refrigerant amount	[gr]	103	
Compr. #2 Tipo di Refrigerante	Compr. #2 Refrigerant Type	-	-	
Compr. #2 Quantità di Refrigerante	Compr. #2 Refrigerant amount	[gr]	-	
Sbrinamento	Defrosting	-	No	
Ventilatore Compressore	Compressor motor fan	-	Si	
Tipo evaporatore	Evaporator type	-	Tubo Skin	
Ventilatore Interno	Internal motor fan	-	No	
Regolazione temperatura interna	Temperature adjustment	-	Controllore-Elettronico	
Tipo Condensatore	Condenser type	-	A fili	
Manutenzione Condensatore	Condenser maintenance	-	-	
Tipo Pre-Condensatore	Pre-condenser Type	-	-	
Manutenzione Pre-Condensatore	Pre-condenser maintenance	-	-	

Illuminazione	Lighting	[Unità] / [Units]	IT	UK
Tipo luci interne	Inner Lights Type	-	-	
Potenza Luci interne	Inner Lights Power	[W]	15	
Tipo luci cassonetto	Canopy Light type	-	-	
Potenza Luci Cassonetto	Canopy Lights Power	[W]	-	

Dimensioni Principali e Peso	Main Dimensions and Weight	[Unità] / [Units]	L	W	P	D	A	H
Esterno (LxPxX)	External (WxDxH)	[mm]	2055		872		983	
Interno (LxPxX)	Internal (WxDxH)	[mm]	1430 / 400		626		740 / 460	
Imballo 140mm Pallet per Camion (LxPxX)	Packaging Dim. 140 mm Pallet - Truck (WxDxH)	[mm]	2150		935		1210	
Imballo 140mm Pallet per Container (LxPxX)	Packaging Dim. 140 mm Pallet - Truck (WxDxH)	[mm]	2150		935		1210	
Peso Lordo	Gross Weight	[kg]	153					
Peso Netto	Net Weight	[kg]	122					

Altre Dimensioni	Other Dimensions	[Unità] / [Units]	L	W	P	D	A	H
Cassonetto (LxPxX)	Canopy (WxDxH)	[mm]	-	-	-	-	-	-
Battiscopa (LxPxX)	Kickplate (WxDxH)	[mm]	-	-	-	-	-	-
Vetro Superiore (LxPxX)	Upper Lid (WxDxH)	[mm]	-	-	-	-	-	-
Vetro Inferiore (LxPxX)	Lower Lid (WxDxH)	[mm]	-	-	-	-	-	-
Cestello (LxPxX)	Basket (WxDxH)	[mm]	-	-	-	-	-	-
Vaschette Gelato (LxPxX)	Ice Cream Trays (WxDxH)	[mm]	-	-	-	-	-	-
Volume Vaschette Gelato	Ice Cream Trays capacity	[l]	-	-	-	-	-	-
Nr. Vaschette Gelato	Ice Cream Tray nr	-	-	-	-	-	-	-
Ripiani (LxPxX)	Shelves (WxDxH)	[mm]	-	-	-	-	-	-
Passo Fili Cestello (da centro a centro)	Basket wires pitch (from center to center)	[mm]	-					
Passo Fili Ripiano (da centro a centro)	Shelf wires pitch (from center to center)	[mm]	-					
Ingombro a terra	Footprint Area	[m²]	1,792					
Superficie Totale Visibile	Total Display Area	[m²]	-					



# HAVO Group

swiss competence for freshness

DOCUMENTAZIONE TECNICA APPARECCHIO FRIGORIFERO  
REFRIGERATING EQUIPMENT TECHNICAL DOCUMENTATION

IT / UK

Modello - Model

**CHF 900 DD**

Marca - Brand

Categoria - Category

**Congelatore Orizzontale per Supermarket  
Horizontal Supermarket Freezer**

**DATI TECNICI / TECHNICAL DATA**

**Altre Specifiche**

Mobile Esterno  
Vasca Interna  
Materiale di isolamento  
Agente espandente  
Densità Isolamento  
Cavo Spina separato per le Luci  
Tipo di Spina  
Luci interne  
Tipo Coperchi  
Materiale Coperchi  
Tipo Porta  
Gas dell'intercapedine  
Resistenza Telaio Porta  
Resistenza Vetro Porta  
Materiale Porta  
Piedini regolabili  
Ruote

**Other Specifications**

Outer Body  
Inner Liner  
Insulation Material  
Foaming agent  
Insulation Density  
Separate Supply Cord for Lamp  
Plug Type  
Internal Light  
Lid Type  
Lid Material  
Door Type  
Filling Gas  
Frame Heater Power  
Glass Heater Power  
Door Material  
Adjustable feet  
Wheels

**[Unità] / [Units]**

-  
-  
-  
-  
[kg/m³]  
-  
-  
-  
-  
-  
-  
[W]  
[W]  
-  
-  
-

IT	UK
Lamiera Acciaio-Zincato-Vern.	Steel sheet-Galvanized-Painted
Lamiera Acciaio-Zincato-Vern.	Steel sheet-Galvanized-Painted
Poliuretano Iniettato	Injected Polyurethane
Iso-Ciclo-Pentano	Iso-Cycle-Pentane
35	
No	No
SCHUKO	
Si	Yes
Incernierati Piani	Hinged Flat
Lamiera Acciaio-Zincato-Vern.	Steel sheet-Galvanized-Painted
-	-
-	-
-	-
Si	Yes

**Capacità**

Volume Lordo (EN23953)  
Volume Netto (EN23953)  
Quantità Cestelli  
Quantità Ripiani  
Nr Lattine frontali per ripiano (330 ml can)  
Nr. Di bottiglie 500ml frontali  
Lattine 330 ml  
Lattine 500 ml  
Bottiglie PET 500 ml

**Capacity**

Gross Volume (acc. to EN 23953)  
Net Volume (acc. to EN 23953)  
Nr of Baskets  
Nr of Shelves  
Facings (330ml can)  
Facings (500ml PET)  
330 ml Can  
500 ml Can  
500 ml PET Bottles

**[Unità] / [Units]**

[lt]  
[lt]  
[pzl] / [pcs]  
[pzl] / [pcs]  
[pzl] / [pcs]  
[pzl] / [pcs]  
[pzl] / [pcs]  
[pzl] / [pcs]  
[pzl] / [pcs]

IT	UK
	840
	777

**Trasporto**

Quantità per Container 20'  
Quantità per Container 40'  
Quantità per Container 40' HC  
Quantità per Camion std (H = 2,60 m)  
Quantità per Camion Mega (H = 3,00 m)

**Transportation**

per 20' container  
per 40' container  
per 40' HC container  
per 13.6 Truck (H = 2,6 m)  
per 13.6 MEGA Truck (H = 3 m)

**[Unità] / [Units]**

-  
-  
-  
-  
-

[pzl] / [pcs]	Volume occupato [%] Occupied Volume [%]
6	45,65 %
12	44,77 %
24	77,44 %
28	78,94 %
28	66,77 %

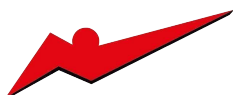

# HAVO Group

swiss competence for freshness

DOCUMENTAZIONE TECNICA APPARECCHIO FRIGORIFERO  
REFRIGERATING EQUIPMENT TECHNICAL DOCUMENTATION

IT / UK

Modello - Model

**CHF 900 DD**

Marca - Brand

Categoria - Category

**Congelatore Orizzontale per Supermarket  
Horizontal Supermarket Freezer**

DISEGNO DIMENSIONALE / DIMENSIONAL DRAWING

Vista / View

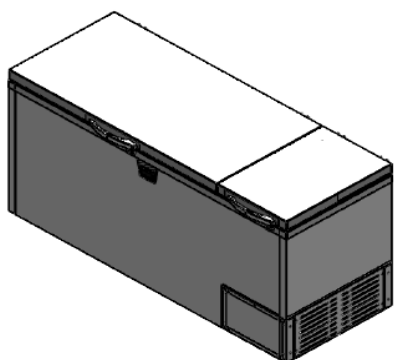
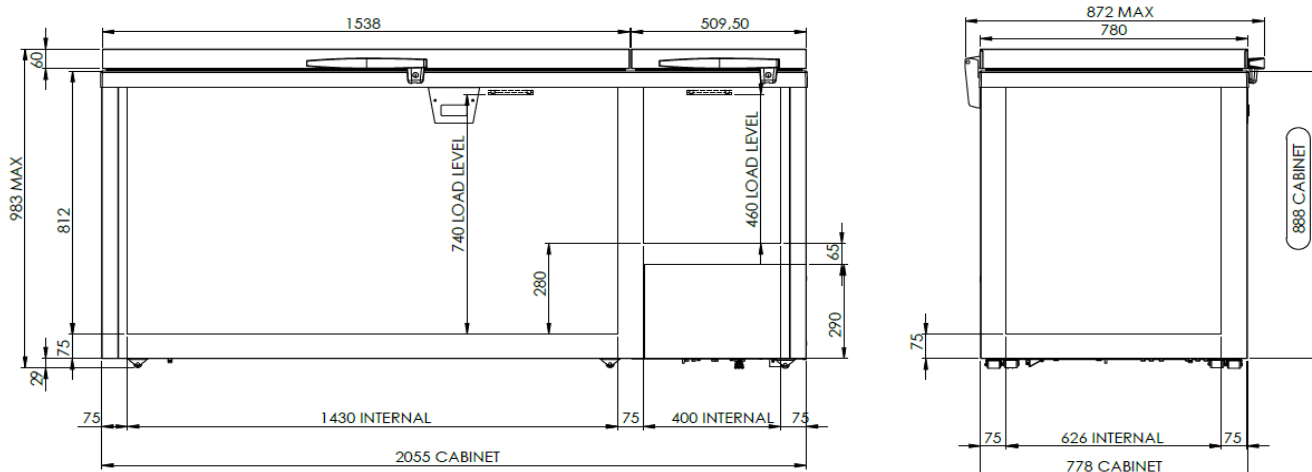

GROSS VOLUME: 840 dm<sup>3</sup>

NET VOLUME: 777 dm<sup>3</sup>

**Dimensioni Principali e Peso**

Esterno (LxPxA)	2055	872	983
Interno (LxPxA)	1430 / 400	626	740 / 460
Imballo 140mm Pallet per Container (LxPxA)	2150	935	1210
Peso Netto	122		

**Main Dimensions and Weight**

External (WxDxH)	[mm]
Internal (WxDxH)	[mm]
Packaging Dim. 140 mm Pallet - Truck (WxDxH)	[mm]
Net Weight	[kg]

**[Unità] / [Units]**

[mm]
[mm]
[mm]
[kg]

L	W	P	D	A	H
2055		872			983
1430 / 400		626			740 / 460
2150		935			1210
					122

**Altre Dimensioni**

Cassonetto (LxPxA)	
Battiscopa (LxPxA)	
Vetro Superiore (LxPxA)	
Vetro Inferiore (LxPxA)	
Cestello (LxPxA)	
Ripiani (LxPxA)	
Passo Fili Cestello (da centro a centro)	
Passo Fili Ripiano (da centro a centro)	
Ingombro a terra	
Superficie Totale Visibile	

**Other Dimensions**

Canopy (WxDxH)	[mm]
Kickplate (WxDxH)	[mm]
Upper Lid (WxDxH)	[mm]
Lower Lid (WxDxH)	[mm]
Basket (WxDxH)	[mm]
Shelves (WxDxH)	[mm]
Basket wires pitch (from center to center)	[mm]
Shelf wires pitch (from center to center)	[mm]
Footprint Area	[m <sup>2</sup> ]
Total Display Area	[m <sup>2</sup> ]

**[Unità] / [Units]**

[mm]
[mm]
[mm]
[mm]
[mm]
[mm]
[mm]
[mm]
[m <sup>2</sup> ]
[m <sup>2</sup> ]

L	W	P	D	A	H
-		-			-
-		-			-
-		-			-
-		-			-
					-
					1,79196
					-

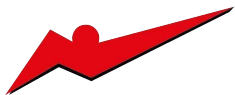

# HAVO Group

swiss competence for freshness

DOCUMENTAZIONE TECNICA APPARECCHIO FRIGORIFERO  
REFRIGERATING EQUIPMENT TECHNICAL DOCUMENTATION

IT / UK

Modello - Model

**CHF 900 DD**













Marca - Brand

Categoria - Category

**Congelatore Orizzontale per Supermarket  
Horizontal Supermarket Freezer**

TARGA DATI TECNICI / TECHNICAL DATA PLATE

Vista / View

MODELLO MODEL		<b>CHF 900 DD</b>									
TENSIONE VOLTAGE		<b>220-240 / 50</b>		<b>V ~ / Hz</b>							
Consumo Energetico Energy Consumption		<b>2,96</b>		<b>KWh/24h</b>		CLASSE DI SICUREZZA (EN 60335-2-89) SAFETY CLASS (EN 60335-2-89)		<b>5</b>			
POTENZA NOMINALE RATED POWER		<b>235</b>	<b>W</b>	POTENZA IN SBRINAMENTO DEFROSTING POWER		-	<b>W</b>				
CORRENTE NOMINALE RATED CURRENT		<b>1,65</b>	<b>A</b>	CORRENTE IN SBRINAMENTO DEFROSTING CURRENT		-	<b>A</b>				
ESPANDENTE FOAMING AGENT	<b>Cyclopentane</b>				<b>15,0</b>	<b>W</b>		-	<b>W</b>		
TIPO REFRIGERANTE REFRIGERANT TYPE	 <sub>1</sub>	<b>R290</b>	 <sub>2</sub>	-	QUANTITA' REFRIGERANTE REFRIGERANT AMOUNT	 <sub>1</sub>	<b>103</b>	<b>gr</b>	 <sub>2</sub>	-	<b>gr</b>
CLASSE CLIMATICA CLIMATE CLASS	<b>EN23953</b>	<b>7</b>	<b>/</b>	<b>L1</b>	CODICE CODE						
MATRICOLA SERIAL NUMER					MATRICOLA PROPRIETÀ PROPERTYNUMBER						
VOLUME LORDO GROSS VOLUME	<b>840</b>		<b>L</b>	Codice a barre Bar code							
VOLUME NETTO NET VOLUME	<b>777</b>		<b>L</b>								
